



Shown with SensorSAFE™



# Symphony Plus™ ice and water dispenser

## 12 CI series countertop with Chewblet® ice machine

### Features

Narrow, 16.12" (40.9 cm) width

12 lb (5.4 kg) ice storage capacity

Integral air-cooled ice machine with up to 425 lb (193.0 kg) daily production of Chewblet ice

- soft, chewable, compressed nugget ice is preferred over cubes<sup>1</sup> and is ideal for patient care
- Quiet Night™ sleep mode turns off ice machine when idle

Designed with sanitation in mind

- automatic self-flushing of ice machine removes impurities
- drain cup provides internal air gap for added protection of food zone components from drain line contaminants
- Agion® silver-based antimicrobial provides protection of key ice and water contact components<sup>2</sup>
- one-hand lever or SensorSAFE infrared ice dispense

Dependable design, easy to service and clean

- cleaning and sanitizing of entire machine takes only 1 hour
- LED control board provides at-a-glance machine status
- panels are easily removed for accessibility to all components
- ice machine parts are common across all Symphony Plus dispensers
- stainless steel evaporator and auger deliver long life

Environmentally responsible

- meets Consortium for Energy Efficiency Tier 2 specifications
- R404a refrigerant has zero ozone depletion potential
- continuous ice making process uses less electricity and water

Durable, attractive dispenser

- stainless steel cabinet with accent trim
- poly drain pan, grille and dispenser lid are corrosion-resistant

Easy installation

- comes fully assembled and installs with three easy connections – electric, water and drain

Warranty

- 3 years parts and labor, 5 years compressor parts

### Accessories

- Base stand with or without factory installed filter (refer to form# 7010)
- 4.00" (10.16 cm) leg kit (item# AF10LBLEGS)
- Pressurized water sanitizing kits (refer to form# 6830)
- SafeCLEAN Plus™ ice machine cleaner
  - 6 x 8 oz (237 ml) bottles (item# 01149954)
  - Carton of 24 x 8 oz (237 ml) bottles (item# 01149962)
- Nu-Calgon® IMS-III sanitizer, 16 oz (0.5 L) bottle (item# 00979674)
- Additional filters (refer to form# 9905 and 8320)
- Additional Symphony Plus accessories (refer to price list)

### SensorSAFE infrared dispense (optional)



SensorSAFE not recommended for use with clear containers or for applications in direct sunlight

### Model configurations

Ice storage capacity	Dispense	Ice machine cooling	Item number
<b>12 lb (5.4 kg)</b>	Lever	air	<b>12CI425A-L</b>
	SensorSAFE	air	<b>12CI425A-S</b>

Ice-only available, add -I  
Example: 12CI425A-LI

### Ice production

Temperatures air/water	70/50 F (21/10 C)	90/70 F (32/21 C)
Air-cooled	425 lb (193.0 kg)	325 lb (147.6 kg)
Energy consumption per 100 lb (45.4 kg) ice	N/A	6.0 kWh air-cooled
Water consumption	12.0 gal (45.4 L) of potable water per 100 lb (45.4 kg) of ice	

Job \_\_\_\_\_  
Item \_\_\_\_\_

## Specification

Ice storage capacity	12 lb (5.4 kg)
<b>W1</b> Width	16.12" (40.9 cm)
<b>W2</b> Width, base stand accessory	17.50" (44.4 cm)
<b>D1</b> Depth, entire dispenser	23.50" (59.7 cm)
<b>D2</b> Depth, drain pan	5.50" (13.97 cm)
<b>D3</b> Depth, base stand accessory	22.00" (55.9 cm)
<b>H1</b> Height, dispenser	32.50" (82.6 cm)
<b>H2</b> Dispense height clearance	9.38" (23.83 cm)
<b>H3</b> Height, base stand accessory	33.00" (83.8 cm)
<b>H4</b> Height, leg kit accessory	36.64" (93.1 cm)
Ventilation clearance	6.00" (15.24 cm) top and right side
Service clearance	12.00" (30.5 cm) top
Utility connection location	through back or bottom
<b>C1</b> 115 V/60/1 electrical	11 amps, 0.8 kW 8.5' (2.6 m) cord w/ NEMA 5-15 90° hospital-grade plug
<b>C2</b> Potable water inlet	3/8" FPT
<b>C3</b> Drain	3/4" MPT
Air temperature	50 - 100 F (10 - 38 C)
Water temperature	45 - 90 F (7 - 32 C)
Water pressure	10 - 70 psi (69 - 483 kpa)
Heat rejection	5000 BTU/hr
Approximate net weight	144 lb (65 kg)
Approximate ship weight	199 lb (90 kg)
Approximate ship weight, base stand accessory	80 lb (36 kg)

NOTE: For indoor use only

SHORT FORM SPECIFICATION: (Choose one) \_\_\_ Ice and water or \_\_\_ ice-only dispenser to be Follett® automatic load in countertop configuration, with 12 lb (5.4 kg) of storage and separate ice and water chutes. Environmentally responsible R404a air-cooled ice machine to have 24 hour production capacity of approximately 425 lb (193.0 kg) of Chewblet compressed nugget ice at water temp. of 70 F (21 C); air temp. of 50 F (10 C). Ice machine equipped with automatic self-flushing and Quiet Night sleep mode. Dispenser to have automatic bin level control to start and stop ice machine. Storage area insulated with CARB compliant non-HFC foam. 8.5' (2.6 m) cord and NEMA 5-15 90° hospital grade plug provided. NSF and ETL listed.

## Dimensional drawing

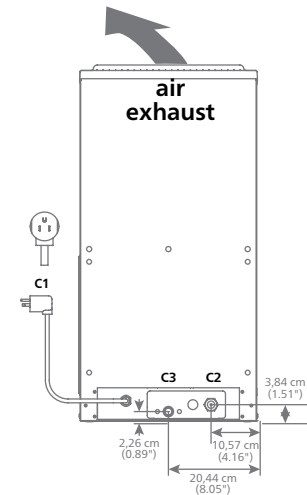
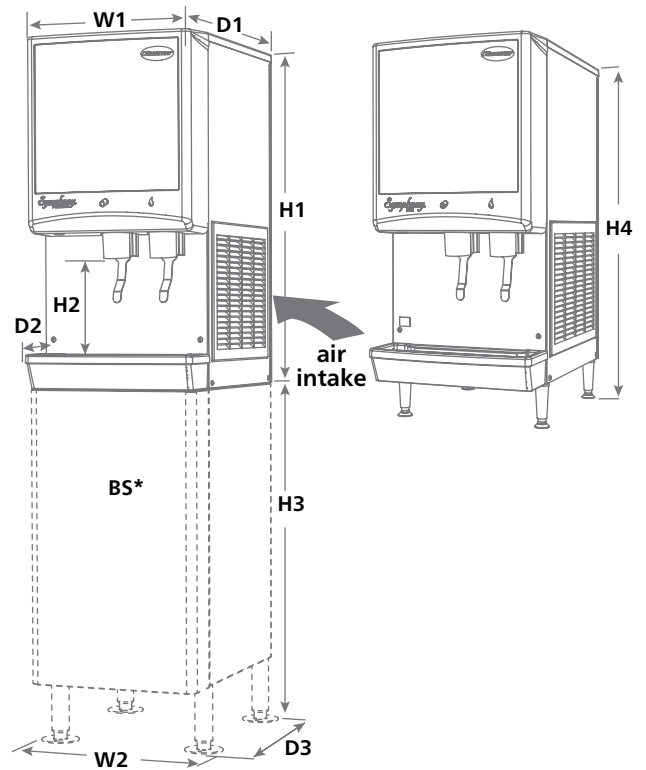

**BS\*** – Base stand sold separately; measurements shown are with base stand legs at lowest position.

See dispenser detail sheet, form# 6675, for counter cutouts.

<sup>1</sup> Independent third party studies. Contact Follett for details.

<sup>2</sup> Disclaimer: Antimicrobial protection is limited to the treated components and does not treat water or ice.

Agion is a registered trademark of Sciescent LLC.

SYMPHONY PLUS, SENSORSAFE, SAFECLEAN PLUS and QUIET NIGHT are trademarks of Follett LLC.

CHEWBLET and FOLLETT are registered trademarks of Follett LLC, registered in the US.

Follett reserves the right to change specifications at any time without obligation. Certifications may vary depending on country of origin.